

2190 Dagenais Blvd. West
LAVAL (QUEBEC)
CANADA
H7L 5X9

TEL: 514.337.4415
FAX: 514.337.4029
info@burcam.com

INSTALLATION INSTRUCTIONS

MODEL 300828BUP

SUBMERSIBLE SUMP PUMP

Your pump has been carefully packaged at the factory to prevent damage during shipping. However, occasional damage may occur due to rough handling. **Carefully inspect your pump** for damages that could cause failures. Report any damage to your carrier or your point of purchase.

MONTHLY MANDATORY CHECK-UP:

1. Inspect the pump and the sump for any obvious condition that necessitates cleaning, correction, adjustment or repair.
2. Clear the sump and the surroundings of any paper, leaves or other debris that might clog the input openings. Remove anything that might float into the sump.
3. Assure that the pump is secure and vertical for proper operation.
4. Assure that there is adequate clearance from any combustible materials or structure. Stored materials must be kept away from the pump. Shelves or cabinet structures must not be in close proximity over the pump.
5. Assure that the motor is securely plugged into a proper GFCI electrical outlet.
6. Test the 'GFCI' outlet by pressing its test switch. This should prove that the outlet is energized and will trip off to protect against a ground fault. Be sure to reset the 'GFCI' by pressing its reset switch.
7. Lift the float to prove that the pump will start when required. (Step 8 below will test submersible pumps with enclosed floats).
8. Put a pail of water (8 liters) in the sump to prove that any check valve present will permit effluent to flow.
9. Observe that the plumbing can carry the effluent safely out of the residence.

Please read these instructions carefully. **Failure** to comply to instructions and **designed** operation of this system, may **void** the warranty.



Marine battery
not included

SAFETY INSTRUCTIONS:

This fine pump that you have just purchased is designed from the latest in material and workmanship. Before installation and operation, we recommend the following procedures:

- A** Check with your local electrical and plumbing codes to ensure you comply with the regulations. These codes have been designed with your safety in mind. Be sure you comply with them.
- B** We recommend that a separate circuit be lead from the home electrical distribution panel properly protected with a fuse or a circuit breaker. We also recommend that a ground fault circuit be used. Consult a licensed electrician for all wiring.
- C** The ground terminal on the three prong plugs should never be removed. They are supplied and designed for your protection.
- D** Never make adjustments to any electrical appliance or product with the power connected. Do not only unscrew the fuse or trip the breaker, remove the power plug from the receptacle
- E** During the installation steps, make sure that the basement is free of moisture or any fluid or water.
- F** Battery acid is corrosive. Avoid spilling on skin or clothing. Eye protection must be worn when handling the battery.

Material required for submersible sump pump application

Submersible sump pump installation

- Desired length of 1 1/2" or 1 1/4" of ABS/DWV pipe to link up the pump to the drain line.
- Sump pit or 1 only sump basin.
- ABS cement.
- Teflon tape.

NOTICE

This unit is not designed for applications to pump salt water or brine .
Use with salt water or brine will void warranty.

Tools

Screwdrivers, hacksaw to cut pipe, knife to assist in pipe cutting, round file to smooth pipe ends, pipe wrench, adjustable wrench to tighten fittings.

Battery

Use only a new fully charged 12 Volt deep cycle marine battery. Electrolyte level must be checked and maintenance must be done in accordance with manufacturer's guideline.

Battery sizes that will fit into the battery box are 24C, 24VCM, 27C, 27CM, and 27F.

Battery recharge time will be different at each installation. Under normal conditions it will take two to four days to bring a deep cycle battery back to full charge after it has been discharged. If electrical power to the house is lost more than once a week, consider keeping a spare, fully-charged battery to replace an exhausted battery for the standby sump pump.

After each start, the battery pump will run for 5 to 30 seconds after the float return to it's original position.

APPLICATION

- This submersible sump pump system is designed for a permanent sump installation.
- To be used in a residential cottage and farm application.

FEATURES

- Water cooled continuous duty motor.
- Thermal and overload protection.
- Piggy back grounded cables.
- An electrical outlet is required.

CAPACITIES:

(115V AC, 60Hz. 1/3 HP, 7.4A) (15A at start)

5'	2600
10'	2100
15'	1600
20'	250 US GPH

FRICION
LOSS IN
PIPE NOT
INCLUDED

(12V)

- Average battery life on a continuous duty cycle:

7 hrs at 4' (1,5m)	4'	1400
9 hrs at 8' (3m)	8'	1200
10 hrs at 10' (4,5m)	10'	1020 US GPH

INSTALLATION STEPS

ELECTRIC PUMP

IMPORTANT NOTICE

Please note before you proceed with the installation of this product that the manufacturer's guideline has to be respected. Failure to comply may void your warranty.

The following are minimum requirements in order to protect your residence from flooding. It is a small investment but it is your personal responsibility to protect your home, family and valuables. Failure to comply with the following requirements may also void your warranty:

- Two (2) pumps have to be installed in the sump pit. The first pump as a primary pump and the second pump as the backup unit.
- Burcam alarm system model 450454 has to be installed to advise you of any malfunctions.
- As sump pumps are electrically powered and activated so to prevent flooding, a Burcam battery powered back up pump model 300403 has to be installed to evacuate the water.

Pump selection, proper and adequate installation are a must to comply with local by-laws and need to be adhered to.

STEP 1 We recommend that you install your pump in a clean location where there is adequate room for servicing at a later date. Protection from freezing temperatures and good ventilation should be considered as well, to provide the pump an environment for long life. **Do not use to pump gas or toxic fuels. This submersible sump pump is designed to pump water only.**

Friction losses in the discharge pipe must be taken into consideration when the horizontal offset is greater than 50 feet. The discharge pipe should be increased from 1 1/2" to 2". This will reduce friction losses and allow the pump to give maximum performance.

More friction losses must also be taken into consideration when many elbows and fittings are installed in the discharge line. Each elbows and fittings must be considered as 1 feet of head.

The float switch of your pump has been pre-set at the factory and does not need any adjustment.

Never run the pump dry. Damage to the seal may occur. Fill pump pit or sump basin with water before turning on the power.

STEP 2 Assuming that you have a sump pit located in your basement floor... Your sump pit must be constructed from concrete, brick, tile or more recently a sump basin made from plastic and/or fiberglass. The size of your sump pit must be 18" in diameter and no less than 25" deep. When pit is ready, proceed to next step.

SUMP PUMP APPLICATION

SEE DIAGRAM ON PAGE 6

- STEP 3** At this step, you have the opportunity to install a 1 1/2" or a 1 1/4" discharge. We recommend a 1 1/2" ABS/DWV discharge. Connect your pipe to the provided piping of the pumps. The check valves are already installed at the pump discharges.
- STEP 4** Install and position your submersible sump pump in the centre of your sump pit or basin and ensure that there is clearance to allow the vertical float switch a free working area without obstructions (pipe, pit's wall, power cord).
- STEP 5** Install your discharge pipe from check valve to the point of discharge or drain. For installation over 50 feet of horizontal position discharge pipe, use a 2" pipe to reduce friction loss.
- STEP 6** The vertical switch provided with your pump is supplied with a serial electrical male plug. Fix the power cord of the pump into the piggy-back receptacle of the switch and plug this one into electrical grounded outlet. We recommend that a licensed electrician be employed to do wiring. Permanently ground the motor in accordance to the electrical codes for your area. Do not use an extension cord to connect your pump to the power source. From your distribution panel to the receptacle, we recommend a wire gauge not smaller than 14 gauge. Use tape or tie wrap to fix power cords to discharge pipe.
- STEP 7** Fill the sump pit or basin with water to test the operation of your submersible sump pump. The motor should start when the water level reaches approximately the top of your pump. Allow the pump to go through several "on-off" cycle to assure satisfactory operation. If needed, see trouble shooting guide in this manual.
- STEP 8** Review your installation with typical diagram. Check all connections for leaks.

MAINTENANCE

Unplug the switch and pump motor power cord. Remove the pump from pit or basin. Remove trash accumulation and dirt from the pump and float switch. Be sure the float switch operates freely after cleaning. If tar or paint has been received in the pit or basin, use kerosene to remove residue from float switch or pump. **Do not use strong paint solvents.**

Remove the screws that hold the strainer or the base to the bottom of the pump body. Pry the base off the pump body carefully. Clean the impeller and volute passage way from any debris which may have become in contact with these parts. Again, If tar or paint has entered pump, clean with kerosene. **Do not use strong paint solvents.** Be sure impeller turns freely after cleaning.

Check and clean away any debris which may be clogging the suction inlet, pump discharge, check valve and discharge line.

Replace screws and return sump pump to sump pit or basin and reconnect to piping.

INSTALLATION STEPS

NOTICE

Installation of this unit may take several hours. Before disabling your main pump, have ready appropriate means of evacuating the sump.

BATTERY PUMP

STEP 1

Turn off power to main pump.

STEP 2

Check valve : If you install your emergency 12 V pump using the same discharge pipe of your main 115V pump, a check valve is required between the T or Y connection and both pumps. We supply a check valve with this emergency pump. Be sure your main 115V pump is equipped with a check valve (see picture 1). These check valves are required to prevent backflow to the sump pit.

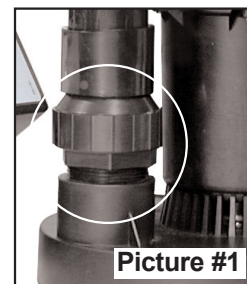

STEP 3

We strongly suggest to run your discharge pipe with 1 1/2" rigid PVC piping.

STEP 4

The emergency pump must be installed at 45° angle (see picture 2) to prevent airlock into the pump body.



STEP 5

Screw the supplied adaptors and check valve to the pump discharge using TEFLON tape (see picture 3).

STEP 6

Glue a 45° fitting to the check valve to maintain the pump in same position as per picture 2 and 3.

STEP 7

Mesure and cut a discharge pipe so that back-up pump is 4" to 8" above the bottom of the sump pit.

STEP 8

Connect the discharge pipe of back-up pump to the discharge pipe of the main pump using a Y and a 45° fitting as per picture 4.



STEP 9

Be sure all connections are well glued.

STEP 10

Attach the float switch to the back-up pump discharge pipe using the enclosed tie-wrap, as per picture 4. The standby pump's float switch should be installed so that it will not activate until standby pump's inlet is under water. Make sure power wires do not interfere with float switch or pump inlet.

STEP 11

Place battery box within 3 feet of the sump and install a 115V AC separately fused outlet within 5 feet of the control box. The electrical outlet must be protected by a ground fault circuit interrupter (GFCI). The area must be also clean, dry and well ventilated.

STEP 12

Fix the control box to the battery box.

STEP 13

Plug the float switch, pump and charger to the appropriate connector as per picture 5. Test pump operation by filling the sump with water while the main pump is unplugged. If the pump operates properly, plug the charger into the GFCI protected outlet to keep the battery charged.



STEP 14

Protect electrical cord from sharp objects, hot surfaces, oil and chemicals. Avoid kinking the cord and replace damaged components immediately.

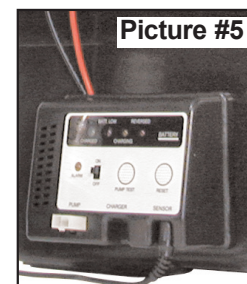

The control box contains a multi-colored indicator lights.

- 1-The green charged light indicates a full charge.
- 2-The red battery low light indicates a low voltage.
- 3-The yellow charging light indicates a charge function in progress.
- 4-The red reversed light indicates a reverse connection on the batterie cables.
- 5-The alarm selector can be put in on or off position as per your choice. If the alarm turns on, the red alarm light will turn on.
- 6-To test the pump operation, push the pump test button.
- 7-To stop the alarm, if in on position, push the reset button.

Note that if activated, the alarm will turn on as soon as the pump turns on. This will warn you that the pump turned on due to a power failure or a primary pump failure.

SUMP PUMP APPLICATION

STEP 3

Determine your choice of discharge pipe size

STEP 2

Sump pit 18" diameter X 25" depth

STEP 7

Fill the basin and test the operation

STEP 8

Review and check connections for leaks

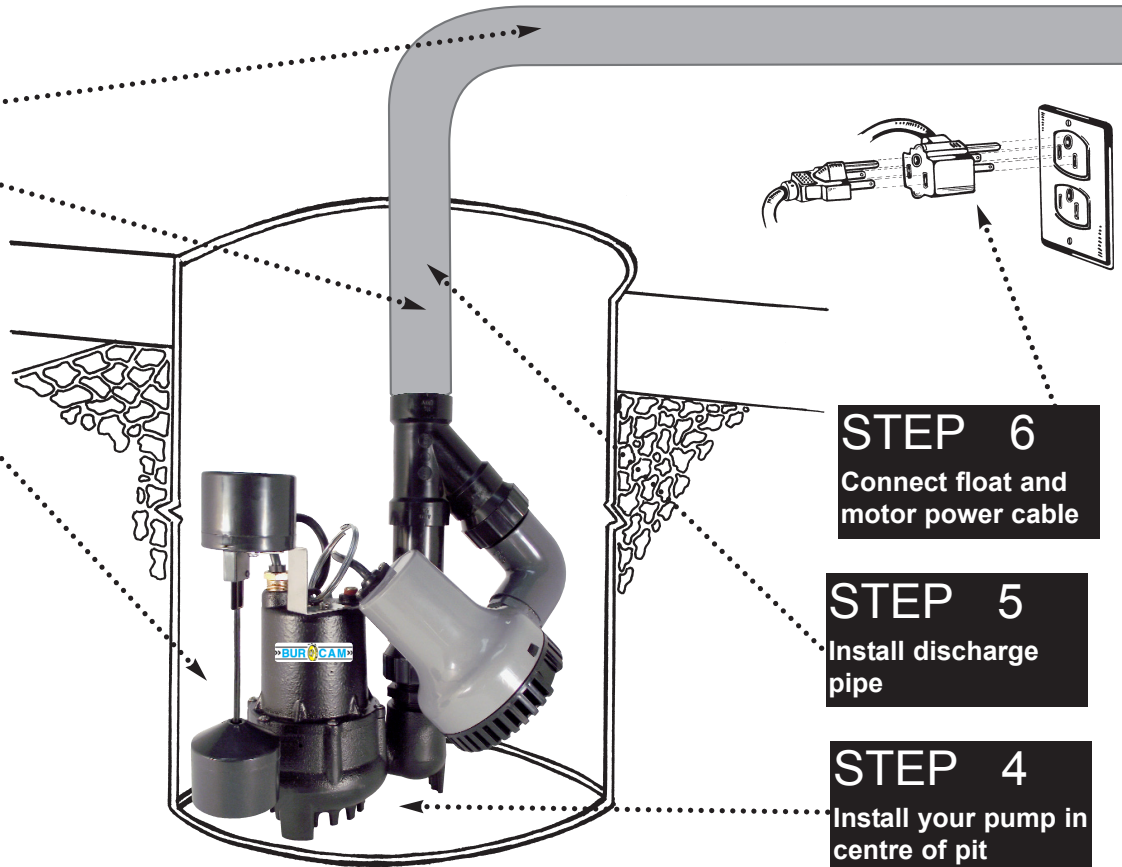

STEP 6

Connect float and motor power cable

STEP 5

Install discharge pipe

STEP 4

Install your pump in centre of pit

REPAIR PARTS

REF. PART	DESCRIPTION	REF. PART	DESCRIPTION
1 310412	Handle	11 310424	O-Ring
2 300450	Bearing	12 310423	Pump body screws (6)
3 310414	Top cover screws	13 310425	Stator assembly
4 310415	Motor casing	14 310426	Packing
5 310416	Rotor & shaft	15 310427	Cable screws
6 310418	Seal cover	16 310428	Power cable
7 350311	Oil seal	17 450447	Vertical float switch
8 310420	Mechanical seal	18 450402	Screws (4)
9 310421	Impeller	19 310411	Switch bracket
10 310422	Pump casing		

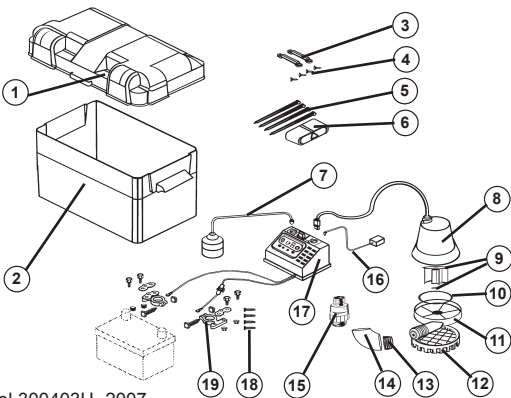
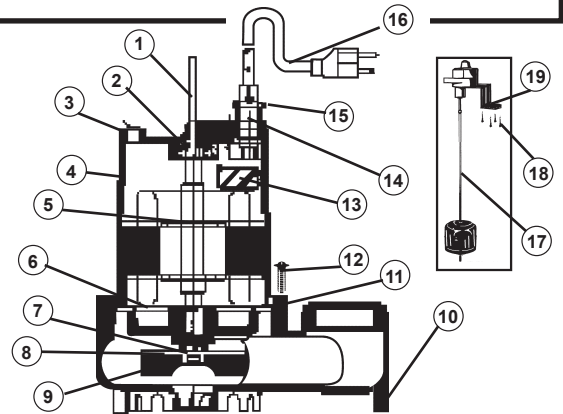

REF. PART	DESCRIPTION	REF. PART	DESCRIPTION
1 310660	Upper box cover	11 310663	Volute
2 310661	Lower box base	12 310662	Suction screen
3 310672	Alternative handles (2)	13 52259	Reducer 1" to 1 1/4"
4 310667	Screws (4)	14 52258	90° Elbow
5 310673	PVC ties (4)	15 350353	1 1/4" check valve
6 310670	Black belt	16 310665	AC Adaptor
7 310666	Float	17 310664	Control box
8 310659	Pump	18 310668	Big head screws (4)
9 310676	Impeller & lock washer	19 310671	Battery cable clamp
10 310677	Pump O -Ring		

Model 300403H 2007

Repair parts may be ordered from your authorized point of sale or from
BUR-CAM PUMPS

TROUBLE SHOOTING GUIDE CHECKLIST

ELECTRIC PUMP

NEVER MAKE ADJUSTMENTS TO ANY ELECTRICAL APPLIANCE OR PRODUCT WITH THE POWER CONNECTED. DON'T JUST UNSCREW THE FUSE OR TRIP THE BREAKER, REMOVE THE POWER FROM THE RECEPTACLE.

TROUBLE	PROBABLE CAUSE	ACTION
Motor does not run.	Switch is off position Blown fuse Tripped breaker Plug disconnected Corroded plug Low water level Thermal overcharge Defective switch/float Defective motor Improper float position	Turn switch to on position Replace Reset Re-install Clean prongs Add water and verify Cool the motor Replace Replace/repair Check movement
Pump does not deliver to full capacity.	Jammed impeller Plugged check valve Blocked suction/inlet Discharge leak Blocked line/pipe Worn impeller Defective motor	Clean Clean/replace Check for debris in pit and clean Repair Check for debris or ice Repair/replace Replace
Pump does not shut off.	Defective switch Float obstruction Blocked suction/inlet	Replace Adjust/check Check for debris in pit and clean

TO THE END CONSUMER

If you have any problems with the product, before advising the store, where you've purchased the pump, please contact us at 514 337-4415, and ask for our sales department, and they will be pleased to help you with any questions you might have, concerning your installation.

TROUBLE SHOOTING GUIDE CHECKLIST

BATTERY PUMP

NEVER MAKE ADJUSTMENTS TO ANY ELECTRICAL APPLIANCE OR PRODUCT WITH THE POWER CONNECTED. DON'T JUST UNSCREW THE FUSE OR TRIP THE BREAKER, REMOVE THE POWER FROM THE RECEPTACLE.

TROUBLE	PROBABLE CAUSE	REMEDIES
Pump won't run.	<p>Connections not secure. Low or defective battery. Float switch unable to swing up and down as needed. Defective or blown fuse.</p>	<p>Check all connections. Check battery and replace if low or defective. Check that float switch tether is long enough to allow pump to operate. Check the internal fuse located inside the control box. Pull the charger from the wall outlet and remove. If the fuse is blown, replace it with a 15 amp automotive type fuse.</p>
Motors hums but pumps won't run.	<p>Defective battery. Impeller is locked.</p>	<p>Check battery and replace if low or defective. Unplug pump and check to see if impeller is free to turn. If impeller is locked, remove the 4 screws on the bottom of the pump to release the housing around the impeller. Remove the obstructions Reassemble pump and reconnect.</p>
Pump runs but pumps very little or no water.	<p>Check valve missing or improperly installed. Obstruction in discharge pipe. Pump not rotated 45°. Pump air locked. Discharge pipe length and/or height exceeds capacity of pump. Low or defective battery.</p>	<p>Check to make sure a check valve is installed and functioning between primary pump discharge and emergency sump pump elbow fitting. Check for obstruction and clear if necessary. Check that pump is rotated 45° in elbow fitting as shown on picture #2. Pump is not install at 45° angle. Clean out to hole and replace cover. If the discharge is too high, a separate line may be required with a lower discharge height. Check battery and replace if low or defective.</p>
Pump cycles too frequently.	<p>Tether length too short on float switch. Main check valve located between the discharge of the primary pump and the emergency pump elbow fitting or the emergency pump check valve not installed or working properly.</p>	<p>Tether length should be at least 2". Adjust if necessary. CAUTION : Ensure tether will swing freely without obstruction. Install check valve or repair as required.</p>

TO THE END CONSUMER

If you have any problems with the product, before advising the store, where you've purchased the pump, please contact us at 514 337-4415 , and ask for our sales department, and they will be pleased to help you with any questions you might have, concerning your installation.